

# PLASDEX™ Cutting System



PLASDEX™ CO<sub>2</sub> LASER CUTTING SYSTEM

The PLASDEX™ Laser Cutting System is an industrial-grade machine optimized to cleanly cut plastic with superior edge quality eliminating post processing operations. The 42" x 42" processing chamber provides ample room to position each mold directly under the laser beam for high-quality QuickCut production. The system includes an oversized exhaust vent mounted directly above the 12" x 12" cutting area to efficiently capture vapors drawn through a series of HEPA filters in the external fume extractor. The system is designed to operate under high-vibration, shock, and dust conditions and incorporates Laser Photonics' proprietary FiberScan C3 LT Windows compatible software.

The PLASDEX™ Laser Cutting System supports both engraving and cutting of the following materials:

- Plastic •Leather •Rubber •Fabric •Wood •Acrylic •Paper/Cardboard
- Cork
- Traffolyte •Matte Board •Melamine •Mylar •Fiberglass •Corian

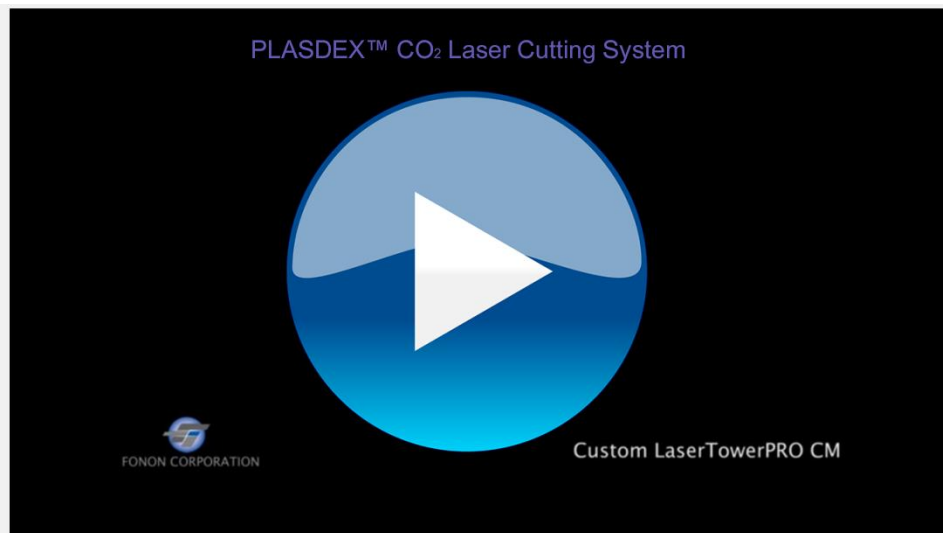

# **PLASDEX Laser Cutting System: Main Features**

**Plug-N-Play, Maintenance-Free with no consumables**

**Long-term industrial-grade reliability with 50,000 MTBF**

**Low voltage power source (110/220 VAC) 8 amps**

**QuickCut Technology**

**CleanCut Technology**

**Small through hole cutting geometries**

**Standard wall plug operation with high electrical efficiency**

**Laser "ON" magnetically locked doors for operator safety**

**Class 1 laser-rated safety viewing port**

**PC-based controller, flat panel monitor, mouse, and keyboard**

**Industrial-grade extruded frame with 19" rack mount design**

**Rotary Indexer for circumferential applications (option)**

**100W CO<sub>2</sub> SLAB laser (standard)**

**2 Year Warranty (standard)**

# PLASDEX Laser Cutting System Dimensions: 400 lbs

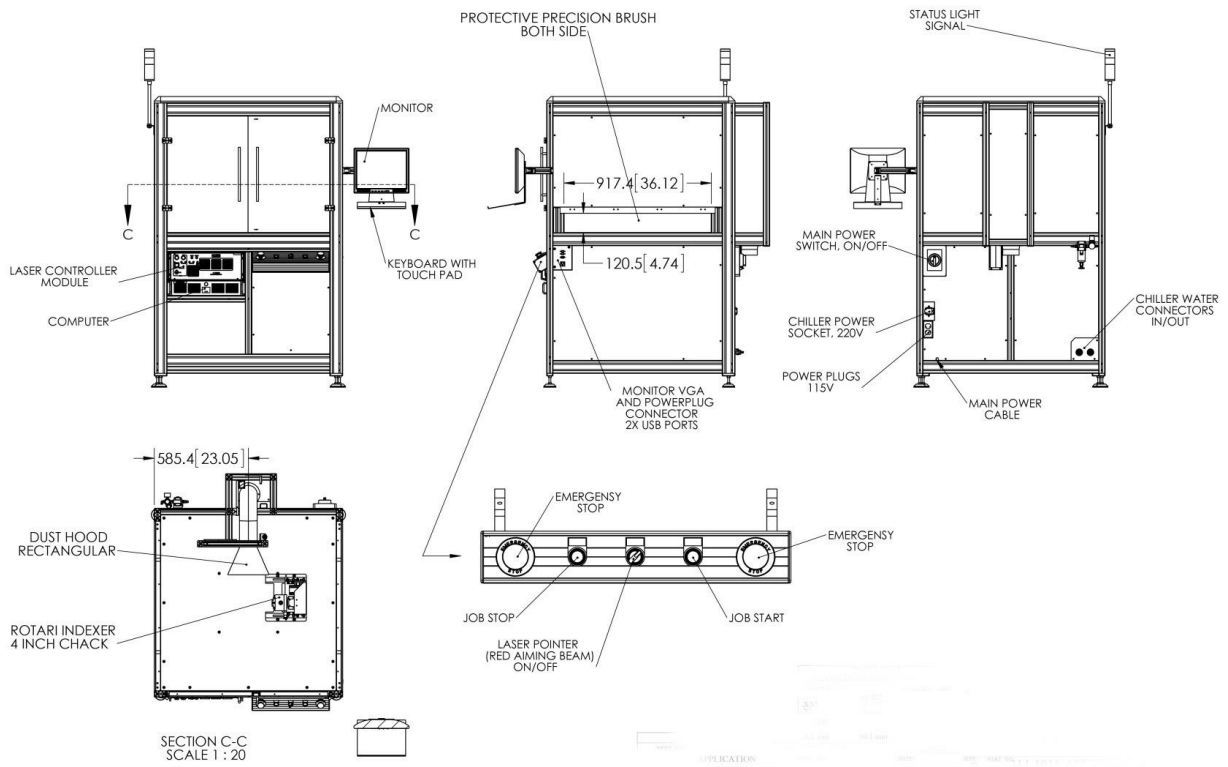
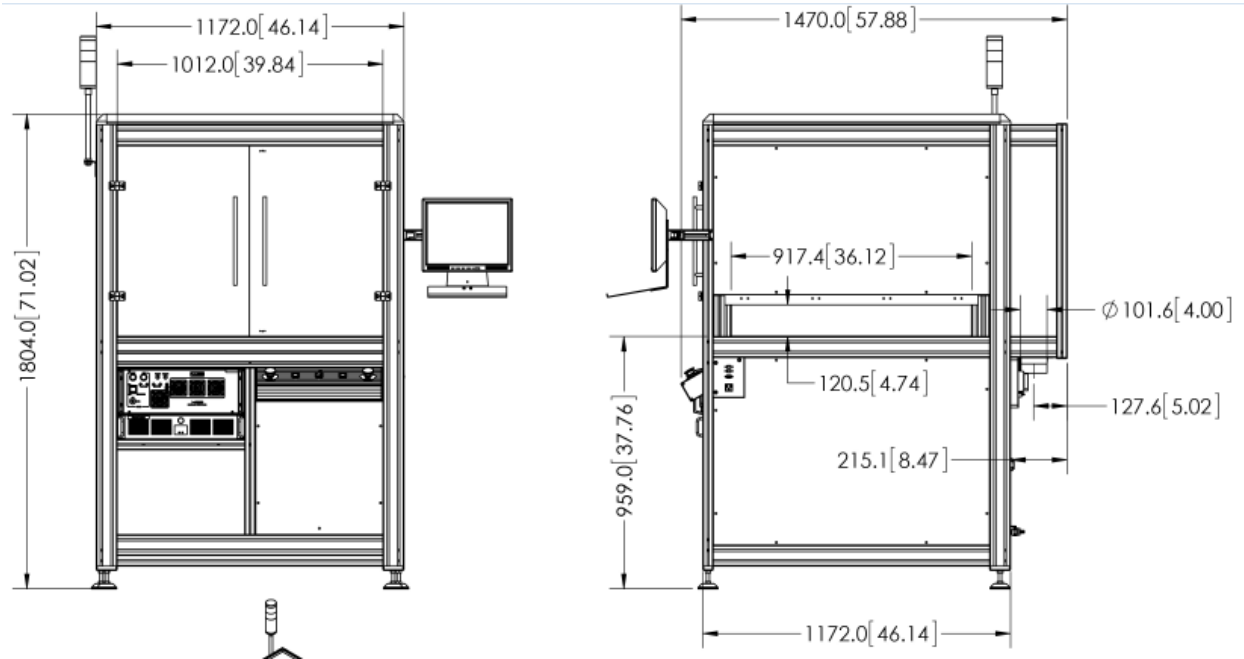

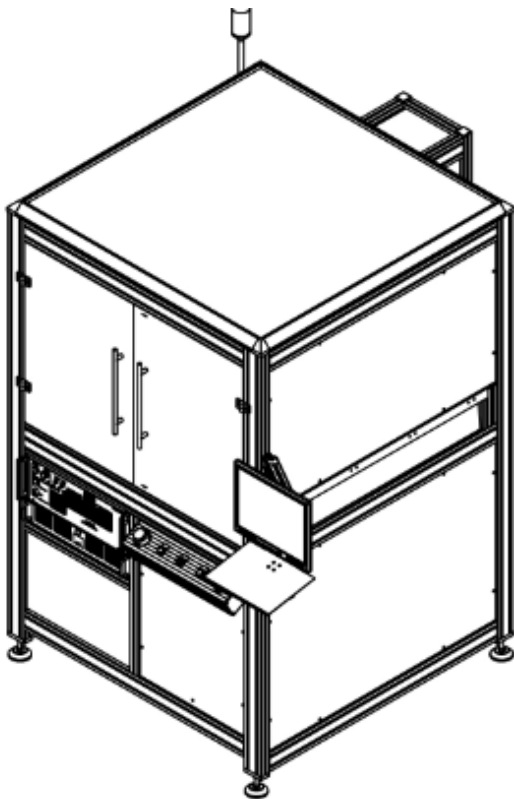
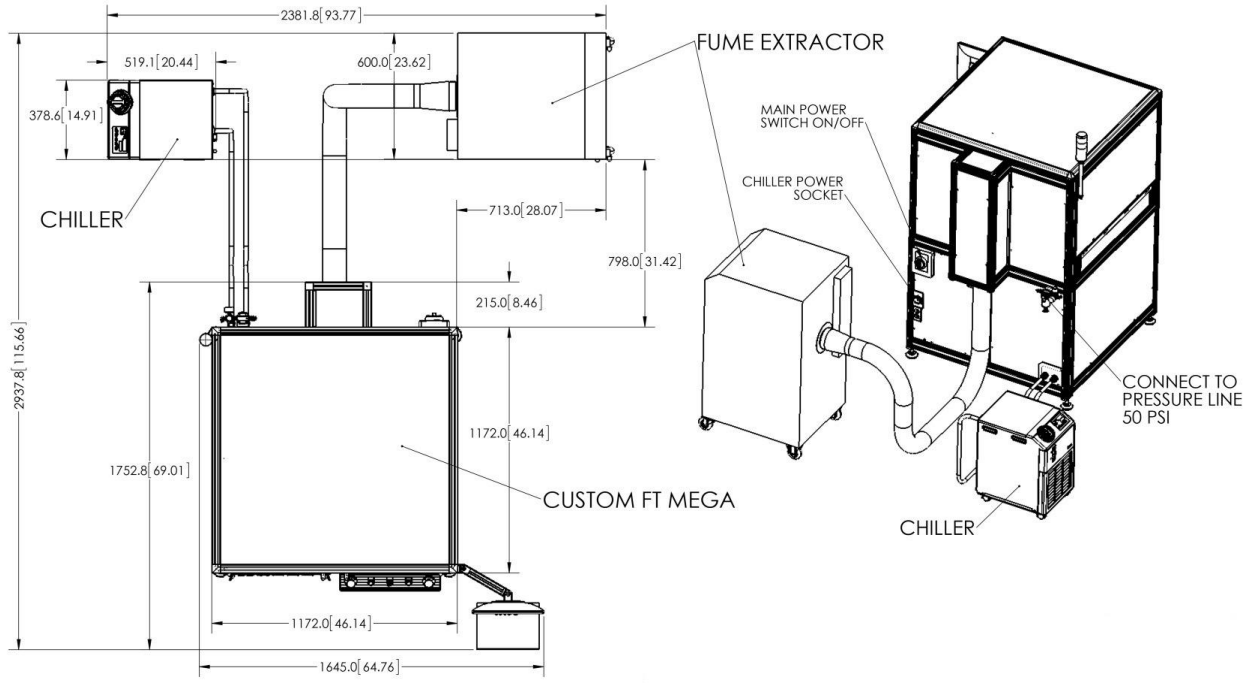

Requirements beyond those listed below will be quoted upon request. Contact Laser Photonics office or visit our website [www.laserphotonics.com](http://www.laserphotonics.com) if you need any assistance determining which capabilities best suit your needs.



Safety Considerations During Operation: 1064 nM wavelength laser light emitted from this laser system is invisible and may be harmful to the human eye. Proper laser safety eyewear must be worn during operation at all times.



21CFR 1040.10 Compliance: Fiber Lasers are a Class 4 laser as designated by the CDRH and meet the full requirements for a stand-alone laser system as defined by 21 CFR 1040.10 under the Radiation Control for Health and Safety Act of 1968. As an added level of security, a redundantly switched safety interlock system helps prevent accidental exposure to excess laser radiation. Plus the system is equipped with an electrical power manual reset, a key-locked laser power switch and a remote interlock connector. Finally,

the system has audible and visible emission indicators with five (5) second emission delay settings. All these features, in combination, constitute the laser radiation safety system which allows the LaserTower™ Series of equipment to be used in a safe and secure manner.

## Raising the Bar of Excellence



**Submit An Inquiry**

**Tel: (407) 804-1000 Toll Free 844-44-LASER (52737)**

**[www.laserphotonics.com](http://www.laserphotonics.com) [fiber@laserphotonics.com](mailto:fiber@laserphotonics.com)**